

MAT288 is a programmable RF combiner, software configurable in:

- Diversity Combiner 8:1 with 6dB gain
- Diversity Combiner 8:4 with 0dB gain
- 2x Diversity Combiner 4:2

MAIN TECHNICAL FEATURES

- ✓ Diversity combiner **8:1** or **8:4** or **2 x 4:2** (sw configurable)
- ✓ Wide bandwidth **150-960 MHz** operation
- ✓ Redundant power supply, AC and DC powered
- ✓ Remote management and monitor of alarms thru Ethernet 10/100 base TX
- ✓ Antenna booster supply toggled on each input independently
- ✓ Voltage and current monitoring on each booster supply with alarm
- ✓ **Programmable attenuators** on each inputs
- ✓ Remote boost control (for gain/bandwidth) with a bidirectional data link thru coax (input BNCs)
- ✓ light window where the user can enter their own text to identify the 8 areas

FUNCTIONAL DRAW (example):

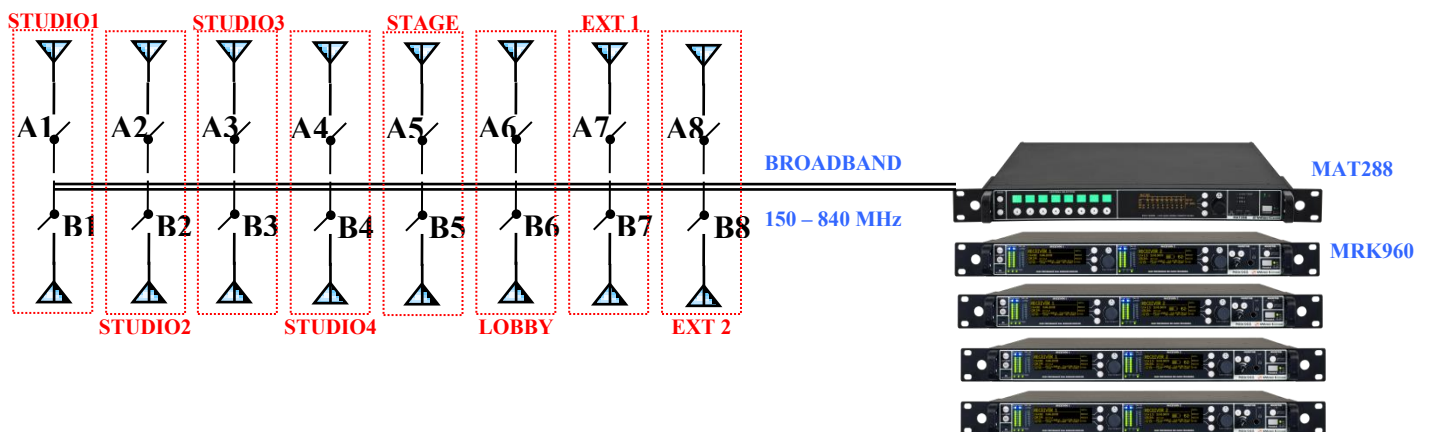

TECHNICAL DATA:

- Power supply : AC connector 90÷264Vac / T2A, 47÷63Hz
DC connector 10÷ 28 VDC (fuse protected) 12A max (optional)
Max power consumption 120W
- Working frequency : 150 ÷ 840 MHz (MAT288), 150 ÷ 960 MHz (MAT288X)
- Amplifier linearity : ± 1 dB (typical)
- "A" / "B" antenna input : 8+8 BNC type connector
- antenna output : 8 BNC type connector
- Impedance : 50 ohm
- Input/output Gain : 6 dB (Combiner 8:1), OIP3=30dBm typ.
0 dB (Combiner 8:4), OIP3=24dBm typ.
6 dB (2 Combiners 4:2), OIP3=30dBm typ.
- Noise Figure : 5.5dB (each channel)
- Antenna booster powering : +12Vcc / 800mA MAX.(ports 1A, 1B and 5A, 5B)
+12Vcc / 230mA MAX.(other ports)
- Configuration/monitor interfaces : 10/100 Base TX Ethernet port
- Display : 64 x 256 OLED (yellow)
- Dimension : Standard rack (aluminum) 19" / 1U.
- Weight : 4,4 Kg

BLOCK DIAGRAM
